

ГАБАРИТНЫЕ РАЗМЕРЫ
OVERALL DIMENSIONS

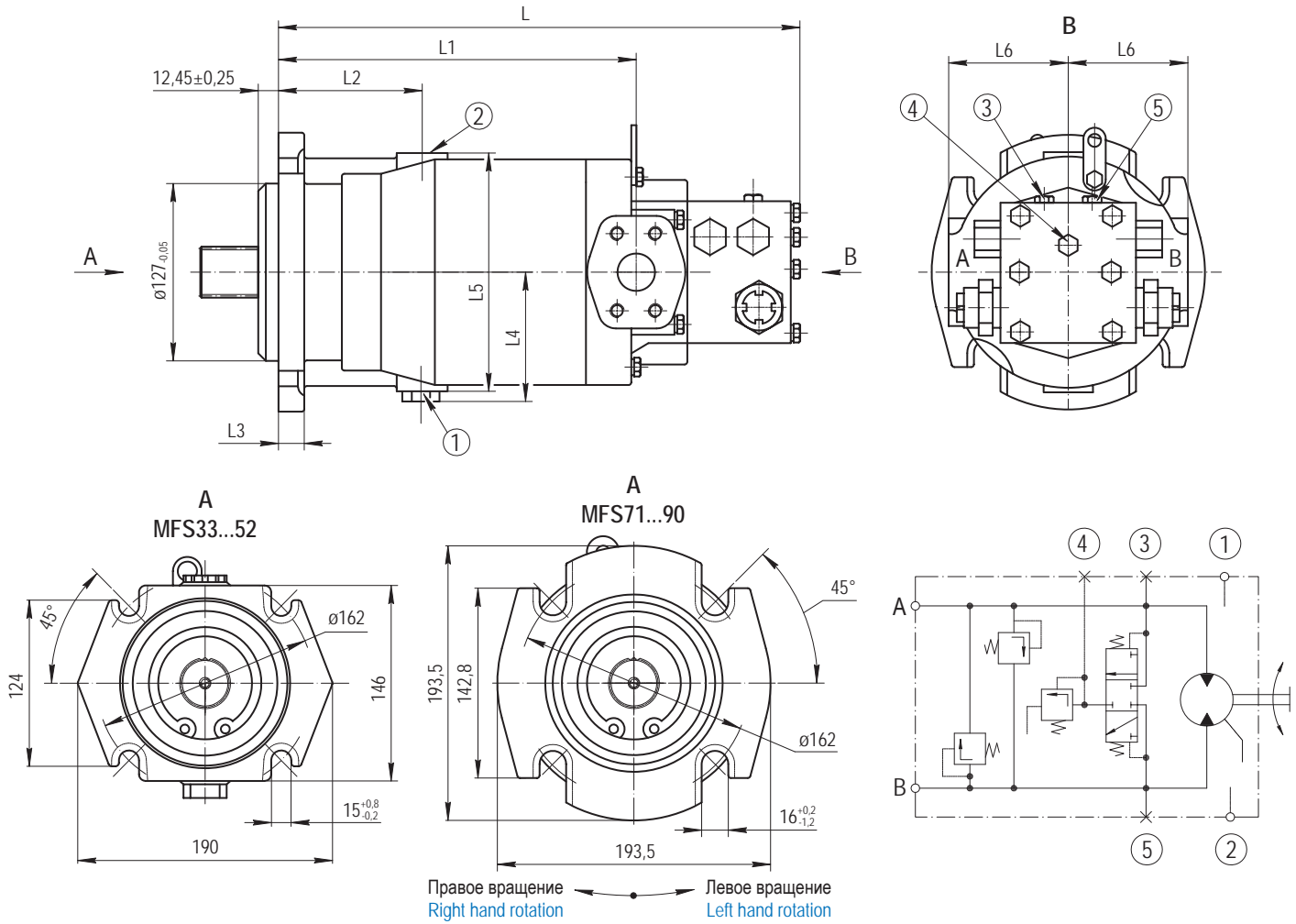

Типоразмер Frame size	Размеры, мм / Dimensions [mm]						
	L	L ₁	L ₂	L ₃	L ₄	L ₅	L ₆
MFS33	340	216	90	16	82	140	81
MFS52	360	235	96		87	152,7	85,8
MFS71	378	255,6	97		98	174	
MFS90	391	270	117,5	17,5	107	192	95,25

ИСПОЛНЕНИЕ ВАЛА
SHAFT OPTIONS

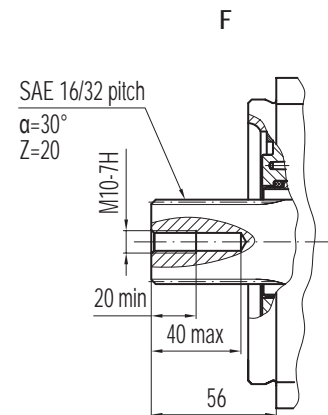
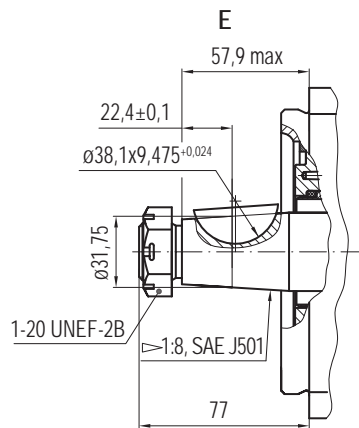
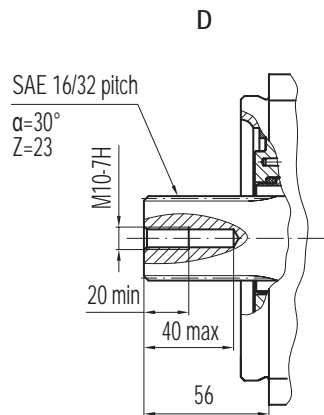
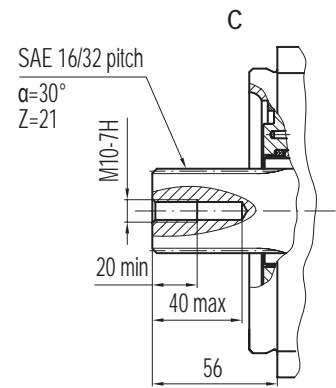
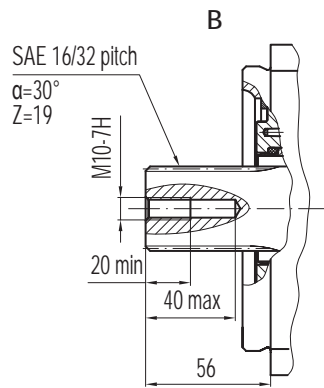
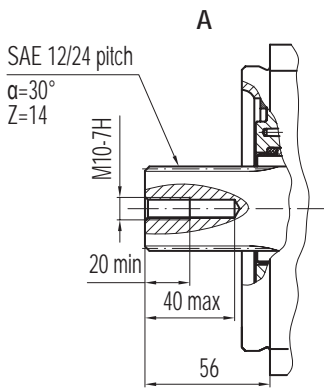

ЦИЛИНДРИЧЕСКИЕ ВАЛЫ,
ИСПОЛНЕНИЕ «К»
CYLINDRICAL SHAFTS, 'K' DESIGN

Типоразмер Frame size	A	D
MFS71	77 max	34,93
MFS90		44,45
Типоразмер Frame size	T	E
MFS71	38,47	7,976x7,976x50
MFS90	48,8	9,576x9,576x50

